

MINI · BOT

Assembly Guide to SparkFun's ProtoSnap MiniBot

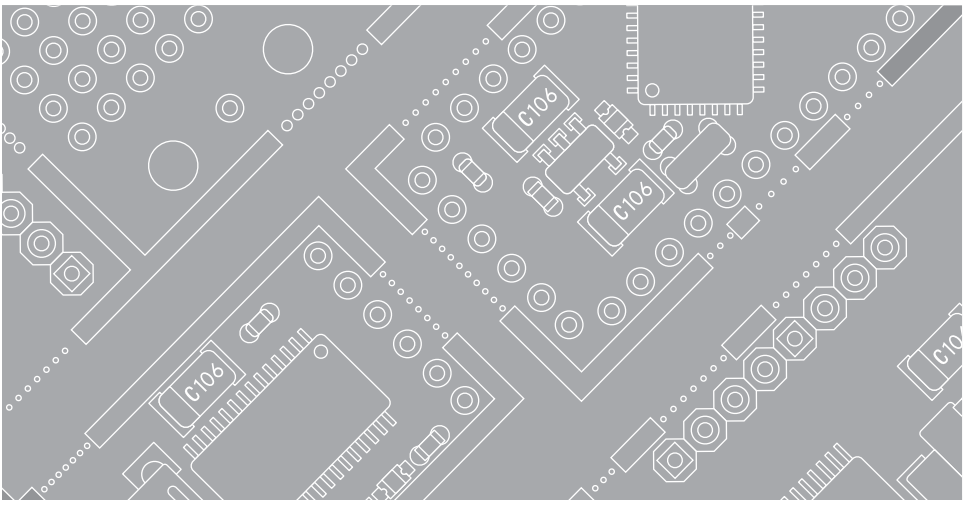

Inventory of Parts





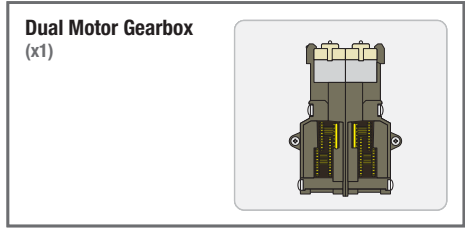
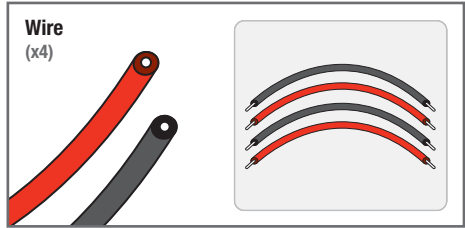
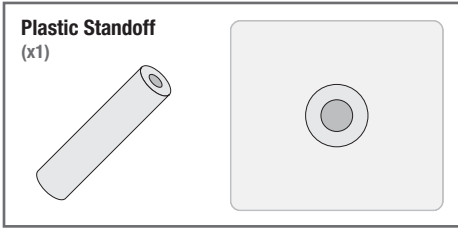
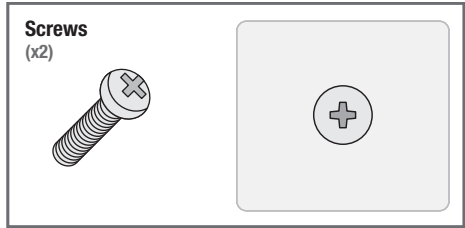
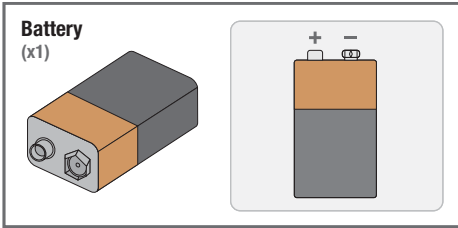
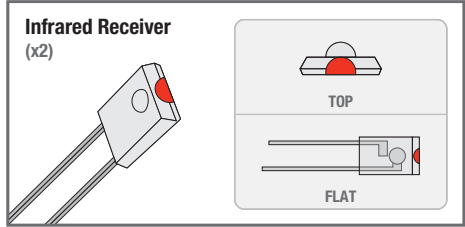
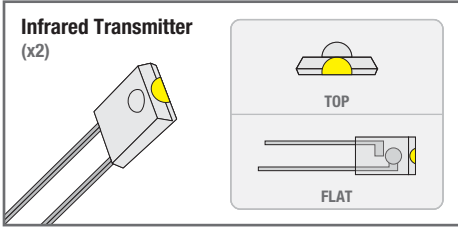
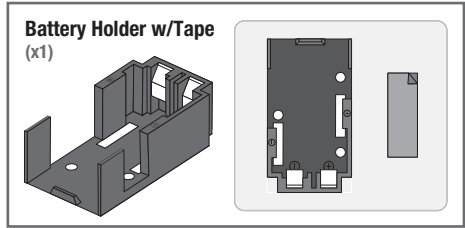
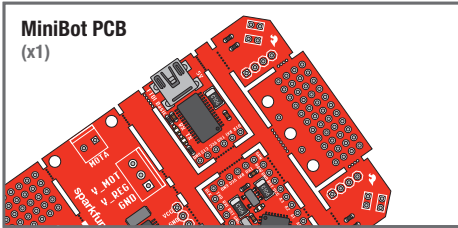

The *ProtoSnap MiniBot* is the newest addition to *SparkFun's* line of *ProtoSnap* products. The *MiniBot* is a complete robotics platform that allows you to build a small, wheeled robot using the included parts and your own tools. The *MiniBot* can be used in conjunction with the *Arduino* programming platform, allowing you to program the platform to suit your individual needs.

For more information go to: www.sparkfun.com/minibot.

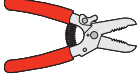

Required Tools:

(not included in kit)

 <p>Soldering Iron</p>	 <p>Wire Cutters</p>
 <p>Spool of Solder</p>	 <p>Wire Strippers</p>
 <p>Sponge for Soldering Iron</p>	<p>* Suggested, not required.</p>  <p>Hobby Knife</p> <p>* Suggested, not required.</p>

Quick Soldering Tips:

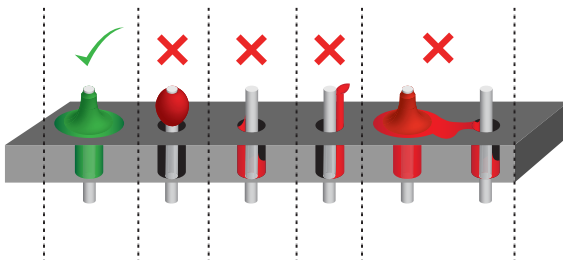
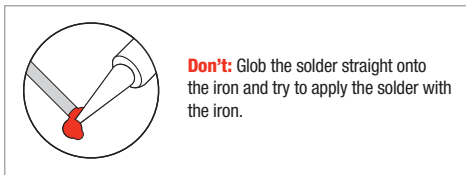
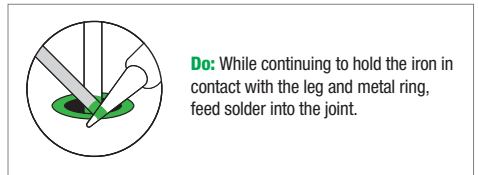
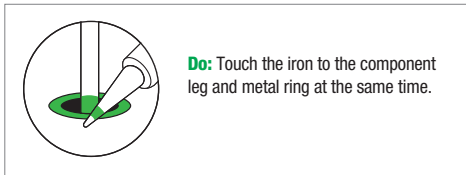
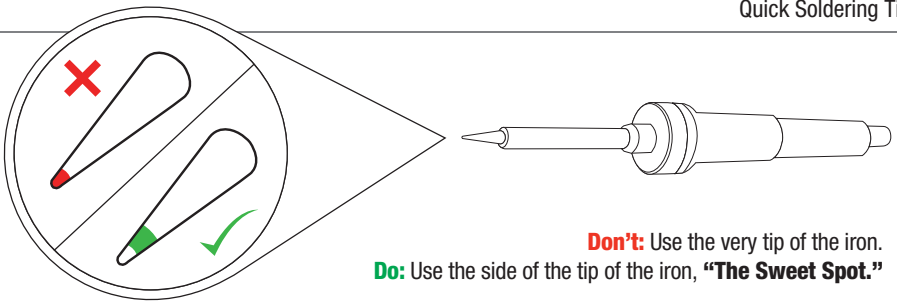

1 Locate the Infrared Transmitter

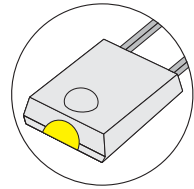
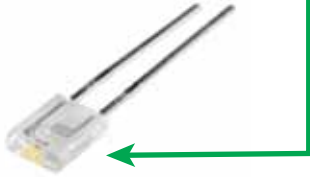

*The transmitter is color coded yellow.

2 Locate the silkscreen footprint on the board and place transmitter through the board. Make sure the lens bump faces forward.

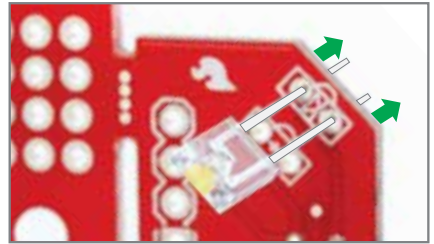
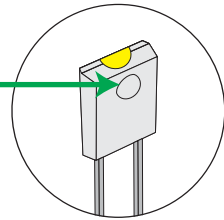
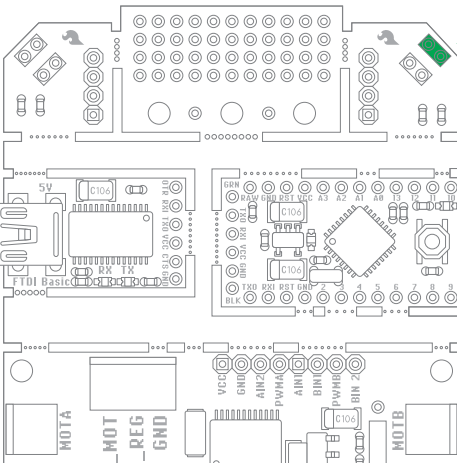

3 Push the legs through the board until the component is flush with top side.

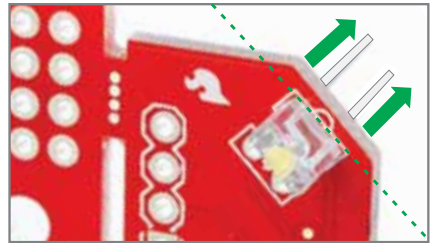

4 Bend legs outward to keep in place.

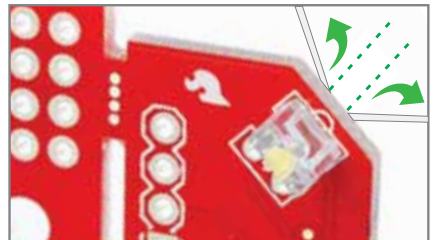

- 5** Flip the board over. Hold the soldering iron's "Sweet Spot" so it touches both the leg and the metal ring. Hold for 2 seconds.

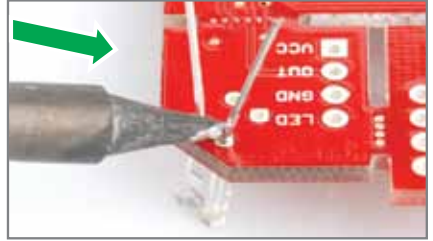

- 6** Feed solder into the joint.

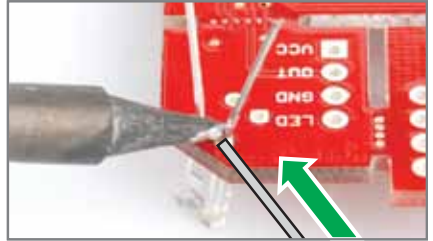

- 7** Pull solder away first. Then iron next.

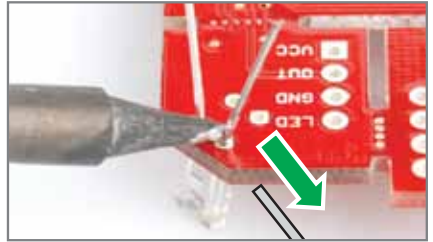

- 8** Your solder joints should look like this - a tiny volcano.

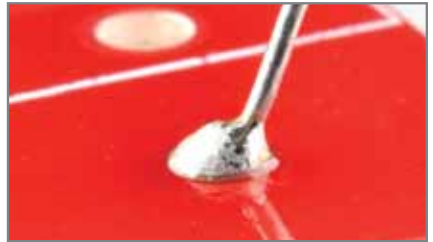

- 9** Clip off any excess legs.



10 Your Infrared Transmitter should look like this.

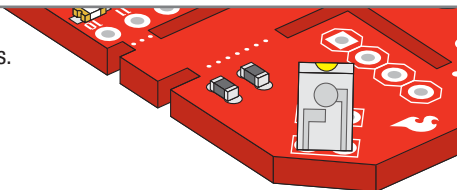

11 Locate the silkscreen footprint and place the second transmitter through the board.

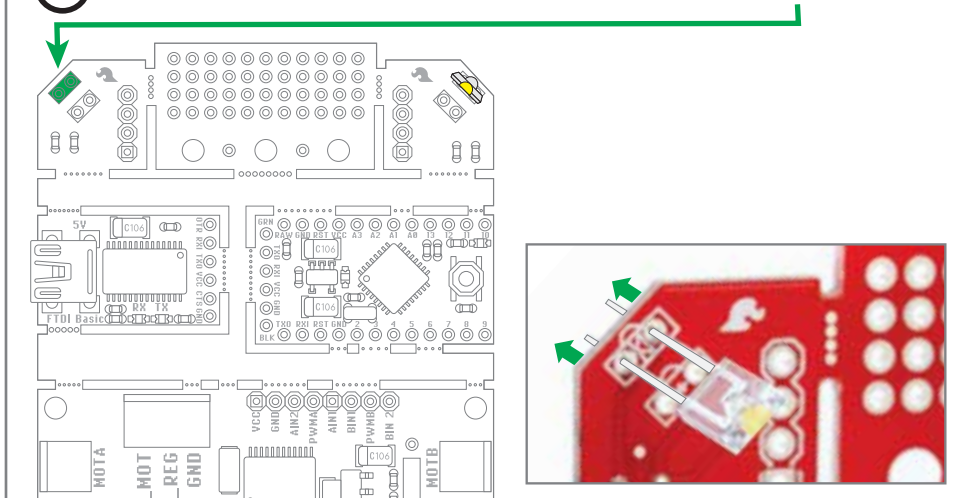

12 Repeat the same process to solder the second transmitter flush to the board. After you complete this the board should now look like the image below.

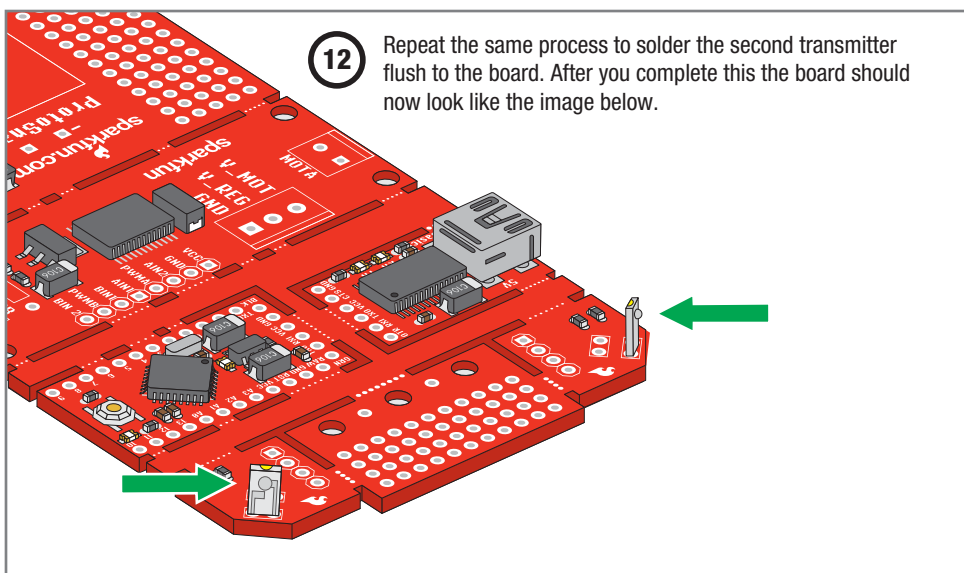

13 Locate the Infrared Receiver

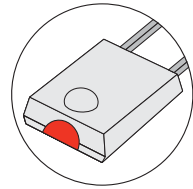

*The receiver is color coded red.

14 Locate the silkscreen footprints on the board for each receiver.

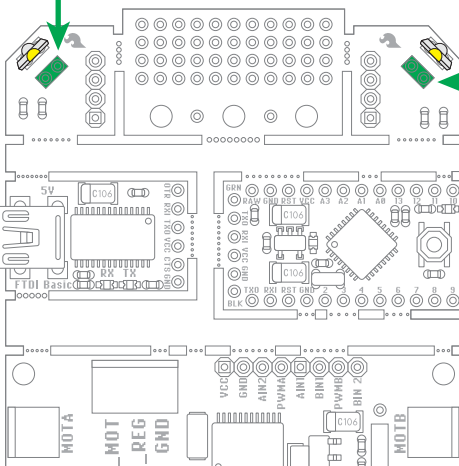

* The receiver needs to sit higher than the transmitter.

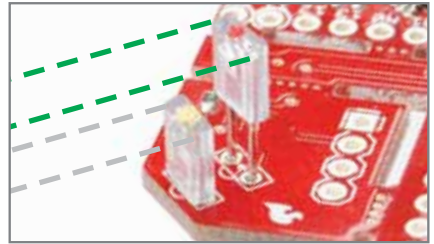

15

Solder the two receivers so they sit just higher than the transmitters. If there isn't enough clearance in heights they will not work properly.

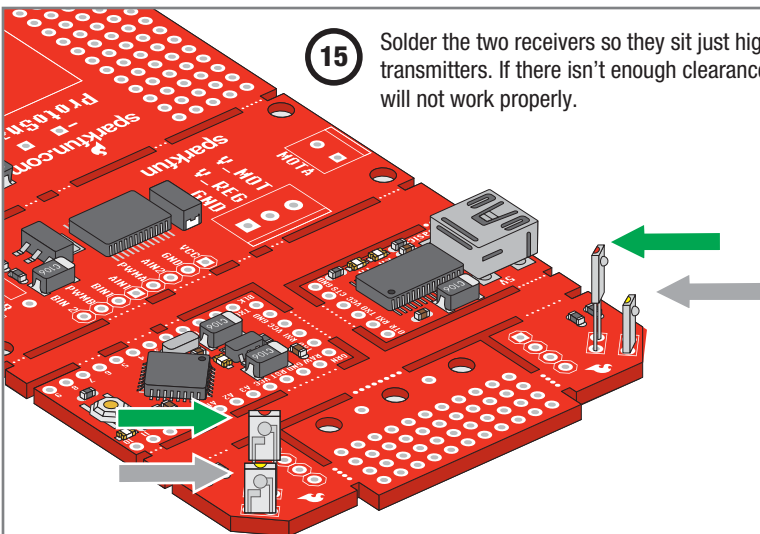

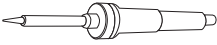

Congratulations! You've successfully soldered the infrared components. Now use the same method to place and solder the rest of the components in the kit!

⚠ BE CAREFUL, THE FOLLOWING STEPS INVOLVE THE TOP AND BOTTOM SIDE OF THE BOARD.

↑ THIS ARROW INDICATES WORKING ON THE TOP SIDE OF THE BOARD.

↓ THIS ARROW INDICATES WORKING ON THE BOTTOM SIDE OF THE BOARD.

← THIS ARROW INDICATES LOOKING AT THE BOARD FROM THE SIDE.

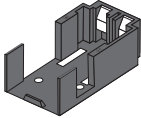

Locate the silkscreen footprint for the battery holder. Follow the directions on the next page. Use the illustration below for reference.

16 Battery Holder

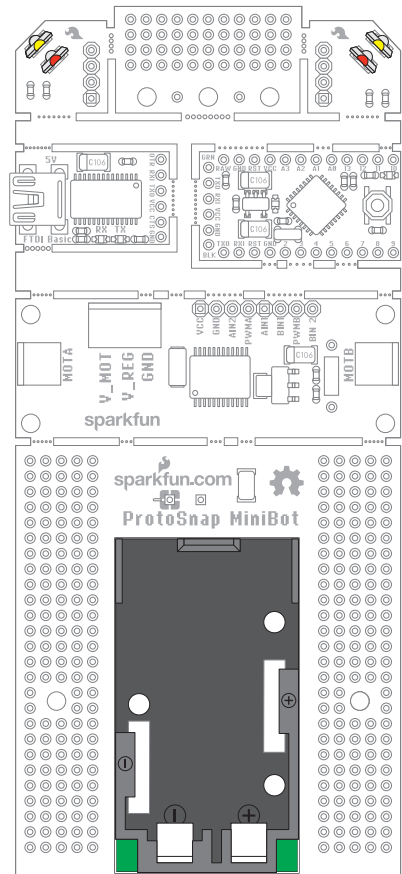
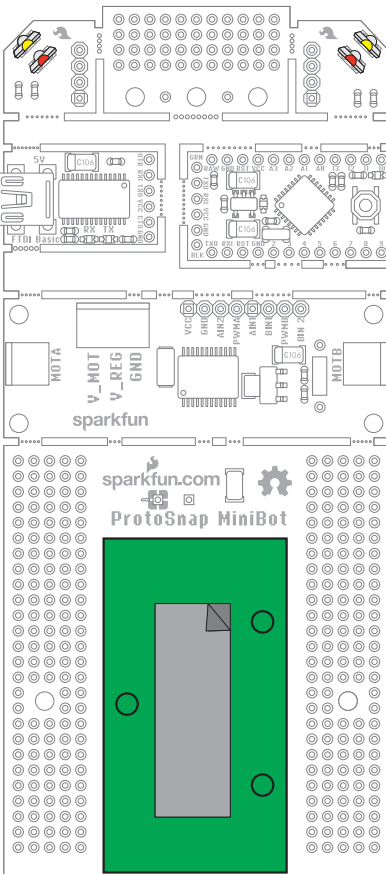

17

Peel one side of the the double stick tape in the center of the footprint. Once placed, peel off the top side to prepare for the battery holder.

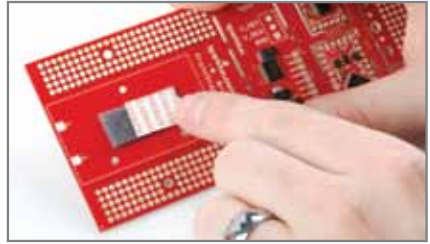

18

Place the battery holder on top of the tape. This will hold it in place as you solder it in from the bottom side.



*Be sure to align the battery holder with the positive (+) and negative (-) markings.



19

Flip the board over and solder. You will need more solder than you used in the earlier steps. Be liberal in feeding solder until completely full.



20

Your solder joint should look like this.

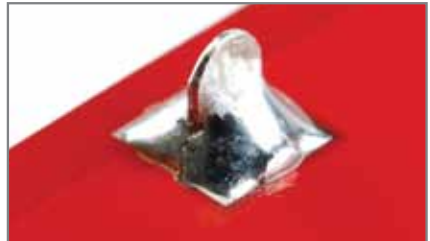

↓ Flip Board Over to Bottom Side

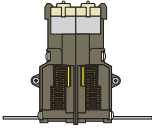

21

Gearbox



For this kit you will need to assemble the gearbox first. You can find the directions for the gearbox inside the Tamiya box. It is important that you assemble the instructions marked "A".



Locate the footprint for the gearbox on the bottom side of the board. Use the screws and nuts that came with the gearbox to secure into place. Then place the tires onto the axle if you have not done so already.

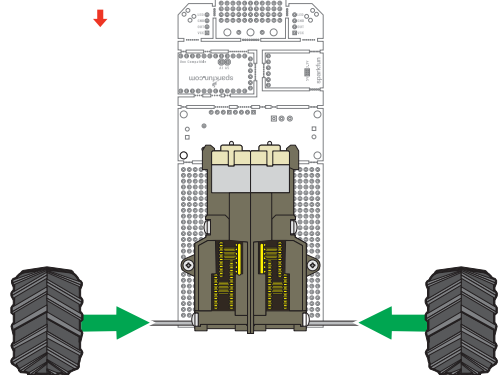
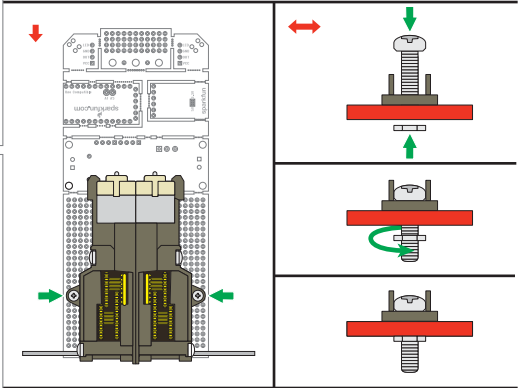
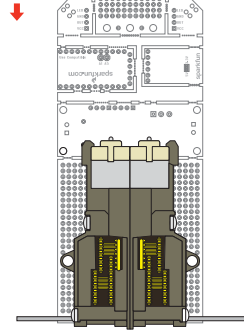
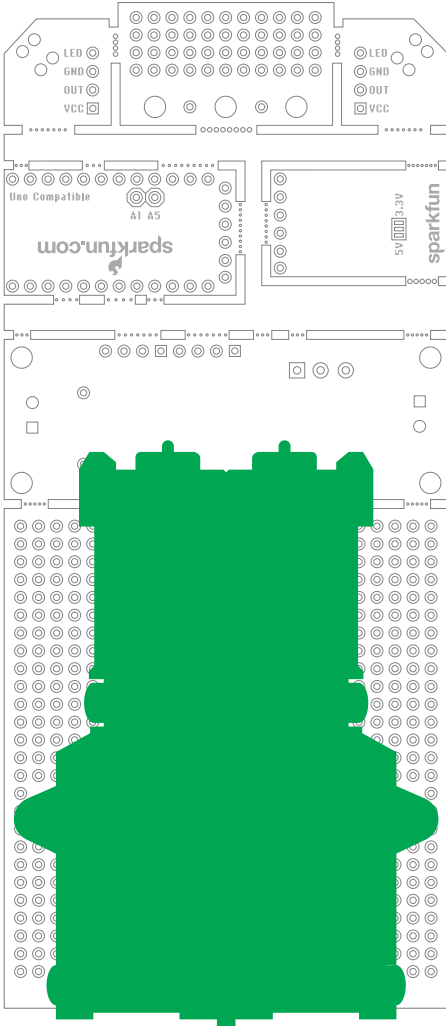

- 22** First we need to pre-tin the motor terminals. Add solder to the two metal connection points on each motor (4 total).

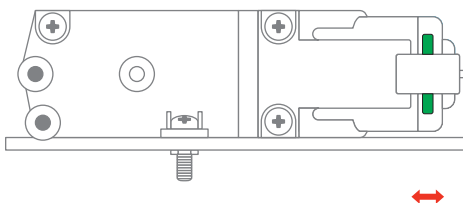
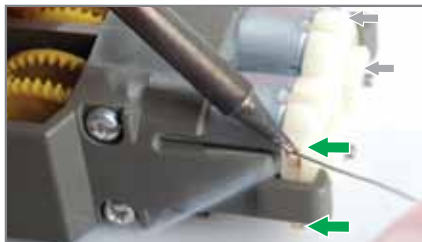
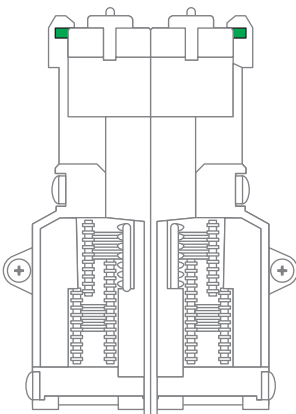

- 23** Strip two pieces of red wire and two pieces of black wire using the wire strippers.



- 24** Solder the red wire to the top and the black wire to the bottom connector for each motor.

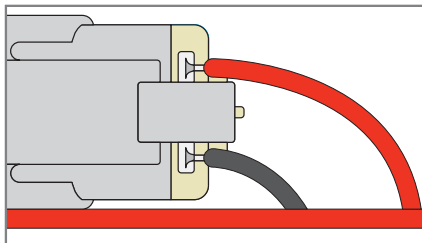

- 25** Feed the two wires for each motor through the relief holes.

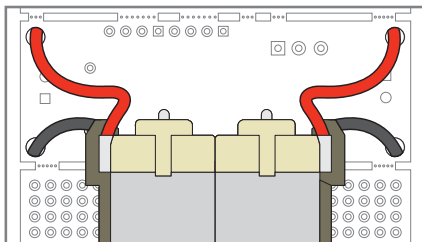

↑ Flip Board Over to Top Side

- 26** Pull wires through top side of board. Measure approximately 1" length from board. Prepare to cut with wire cutters.

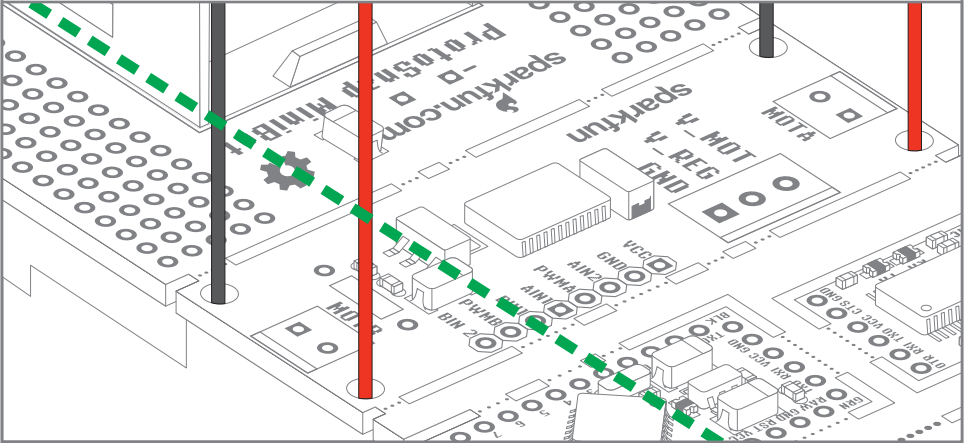

- 27** Use wire cutters to cut the 1" length on all four wires.



- 28** Use wire strippers to strip each wire end.



Attach the plastic standoff

- 31** Place the screw through the center hole. From the bottom twist the standoff until all parts are flush.

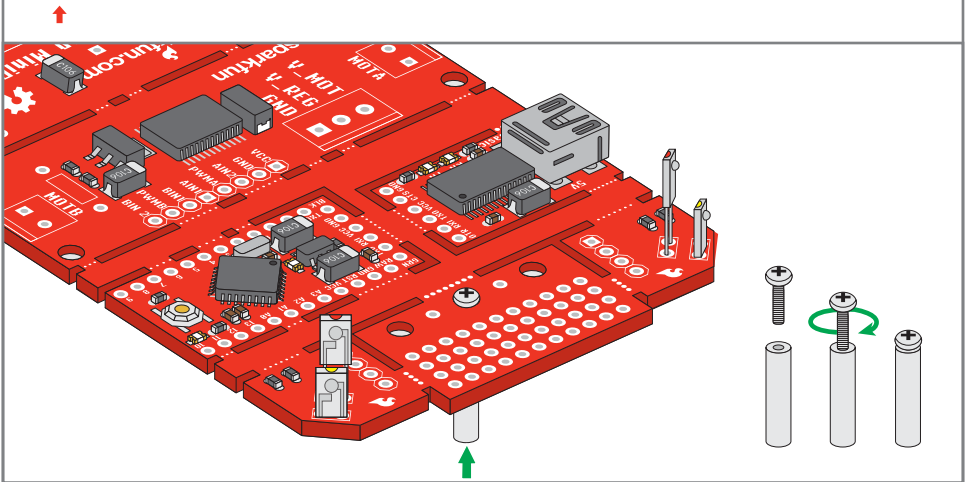

- 32** Add additional screw to bottom of standoff to reduce drag and improve durability.

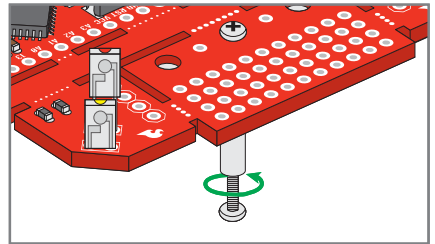

- 33** *Congratulations, you are done!*
Place the 9 volt battery into its holder to turn your MiniBot "on".

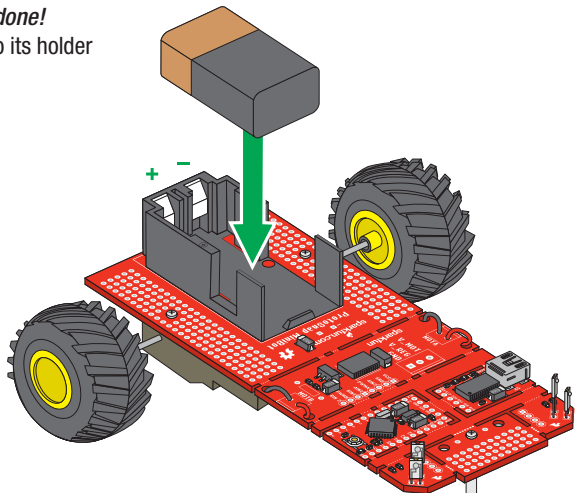

↑ Top:

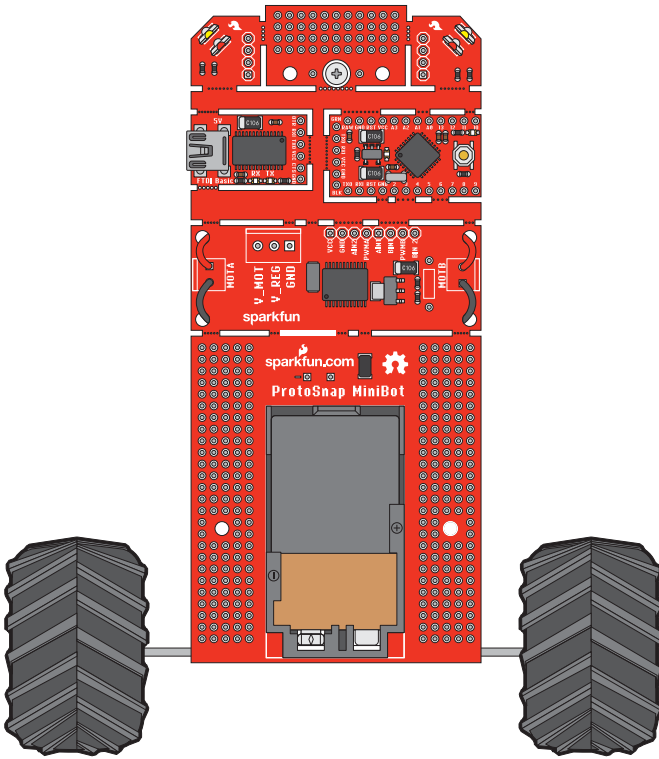

↓ Bottom:

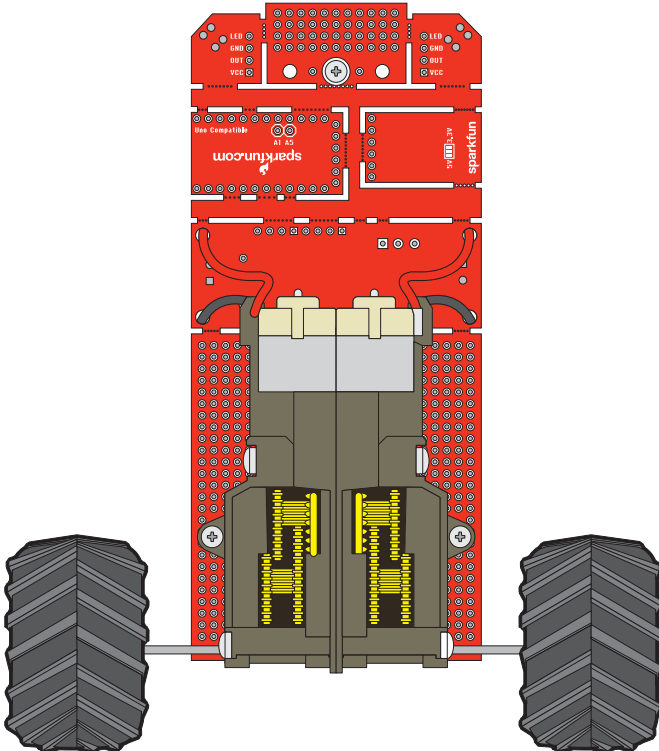



What is ProtoSnap?

ProtoSnap is a new line of SparkFun products that make starting out in electronics easier and more intuitive. Each ProtoSnap product is composed of several different components that come pre-wired to be used easily. When you have reached the limits of your ProtoSnap in its current form, you can snap apart the individual components and repurpose them for other projects.

How Can I Expand the MiniBot?

The MiniBot is designed with three prototyping areas that give you the ability to add more functionality to your vehicle. Using these areas of the PCB, you could add a manipulator, like a claw or gimbal-mounted gripper, or additional sensors, such as ultrasonic range finders or compass and gyro combinations. There is no limit to the combinations you can create!

Soldering Information:

The tip of the iron is normal 700 F, hot enough to melt metal. It is normal for the handle of the soldering iron to heat up a bit. Hold it like a pencil and move your hand further away from the top if the heat is uncomfortable. The solder smokes because the rosin inside the solder is burning off - it's not harmful!